

# TRION<sup>®</sup>

Indoor Air Quality



READ AND SAVE THESE INSTRUCTIONS

*UNIT NOT FOR COMMERCIAL USE*

**Mister-MINI<sup>®</sup>**

Duct Mounted Atomizing Humidifer

Duct Mounted Atomizing Humidifier

# Mister-MINI™

## Table of Contents

Introduction.....	3
Specifications .....	3
Capacity Selection Chart.....	4
Output Capacity.....	5
Installation	
Location Selection.....	6
Mounting .....	7
Wiring.....	8
Plumbing.....	9
Start-up & Operation.....	10
Maintenance	
To Clean and Inspect .....	11
To Check for Leaks .....	11
To Clean Spray Nozzle .....	12
To Clean Solenoid Valve .....	13
Unit Diagram and Parts List.....	14
Warranty .....	15

### Caution:

**Read this manual carefully and completely before installing this product. Installation and maintenance should be completed by qualified personnel.**

## Introduction

The benefits of a properly humidified environment (35-50% Relative Humidity) are many. They include both personal comfort as well as the preservation of furniture, draperies, carpets, wooden floors and cabinets, paintings, pianos, etc. Your home can be more comfortable at a lower temperature (i.e.: 68° F) at 35-50% Relative Humidity (RH) than at 71° to 72° F without controlled humidity. Since every degree of temperature setback represents about 3% of your heating costs, this can possibly represent a significant annual savings. During the heating season, cold air infiltrates the home and must be heated. When heated, this air dries out and greatly increases its capacity to hold more moisture. By using a humidifier, a source of water is provided to satisfy this increased moisture holding capability, rather than having it drawn from our body surface and the surrounding furnishings in the home.

**DO NOT** install the humidifier where freezing conditions could occur or where accidental overflow could cause water damage to the home or property.

For any installation in areas where water damage could occur, **always** install a drain safety pan, plumbed to a suitable drain.

## Specifications

Model	Mister-MINI
Type of Unit	Atomizing/Evaporative
Duct Position	Supply Duct
GPD @ 140°F	12.5 Gallons per day @ 60 psi
GPD @ 120°F	12.5 Gallons per day @ 60 psi
GPD @ 100°F	Not Recommended for Temperatures <120°F
Voltage	24 VAC 3 watt 0.125a
Unit Dimensions	4.25"W x 3.88" D x 4.25" H
Duct Opening	3.125" W x 3.125" H
Shipping Weight	3 lbs
What's in the box	(1) Humidifier (1) Wall/Duct Mount Humidistat (1) Instruction Manual (1) Mounting Template
Features	5-Year Warranty

## Capacity Selection

**The table below is for reference only and is based upon the following:**

- Inside temperature of 70°F / 35% relative humidity
- Outside temperature of 20°F / 70% relative humidity
- 8 foot ceiling height
- Internal moisture gain of one pound per hour
- Furnace on-time 70%

**The chart uses Standard ASHRAE definitions:**

A "Tight Home" is assumed to be well insulated with vapor barriers, tight storm windows and doors, and a dampered fireplace. Air exchange rate of .5 changes per hour.

An "Average Home" is insulated and has a dampered fire place, but there are no vapor barriers, storm doors, or storm windows. Air exchange rate of 1.0 changes per hour.

A "Loose Home" is generally one constructed before 1930, has little or no insulation, no storm doors, storm windows, weather stripping or vapor barriers, and often no effective dampening of fireplaces. Air exchange rate is as high as 1.5 changes per hour

Sq. Footage of Home	Tight Home (GPD)	Average Home (GPD)	Loose Home (GPD)
1000	0.5	5.0	10.0
1500	3.0	10.0	16.5
2000	5.0	14.0	24.0
2500	7.5	19.0	30.5
3000	10.0	23.5	37.5
4000	14.5	33.0	51.5

## Output Capacity

Increasing or decreasing the nozzle size or supply water pressure can vary the output capacity of this humidifier. It is recommended that the humidifier NOT be used with water pressures below 40 PSI, otherwise, the mist may be adversely affected.

This humidifier comes standard with a .75 GPH (oil) nozzle with a hollow spray pattern. Alternatively sized nozzles may be purchased from your local HVAC supply house or plumbing supply outlet. If the water pressure fluctuates or is excessive, a pressure regulator should be installed in the water line supplying the humidifier.

The following chart illustrates the capacity of different nozzles at varying water pressures. The capacity listed on the nozzle is for #2 fuel oil at 100 psi and should not be considered relative to the water capacity of this humidifier.

Nozzle Pressure (PSI)	Nozzle Size							
	0.4		0.5		0.75		1	
	GPH	GPD	GPH	GPD	GPH	GPD	GPH	GPD
40	0.23	5.5	0.28	6.8	0.43	10.2	0.57	13.7
45	0.24	5.8	0.30	7.2	0.45	10.9	0.60	14.5
50	0.25	6.1	0.32	7.6	0.48	11.5	0.64	15.3
55	0.27	6.4	0.33	8.0	0.50	12.0	0.67	16.0
60	0.28	6.7	0.35	8.4	0.52	12.5	0.70	16.7
65	0.29	7.0	0.36	8.7	0.54	13.1	0.73	17.4
70	0.30	7.2	0.38	9.0	0.56	13.6	0.75	18.1
75	0.31	7.5	0.39	9.4	0.58	14.0	0.78	18.7
80	0.32	7.7	0.40	9.7	0.60	14.5	0.80	19.3
85	0.33	8.0	0.41	10.0	0.62	14.9	0.83	19.9
90	0.34	8.2	0.43	10.2	0.64	15.4	0.85	20.5
95	0.35	8.4	0.44	10.5	0.66	15.8	0.88	21.1
100	0.36	8.6	0.45	10.8	0.68	16.2	0.90	21.6

**NOTE:**

Due to the operation cycle of the furnace and humidifier, it may take from 2-5 days to reach the proper humidification level.

## Installation

When selecting a location for the installation of your humidifier, certain conditions must be met for its proper operation. The recommended location for this humidifier is on the warm air supply plenum, approximately 3 inches downstream of the furnace discharge. The air temperature must be at least 120°F in order for the temperature switch to operate properly. In narrow plenum/duct arrangements, the humidifier should be mounted on the narrow side of the duct. Select a location so that the spray from the nozzle will not impinge on the furnace fan, control switches, air conditioning or heat coils, or walls of the duct.

The humidifier should be mounted so that the furnace air carries the mist away from the humidifier temperature switch. The direction of airflow is indicated inside of the humidifier housing and on the rating label on the side of the humidifier.

**DO NOT** install the humidifier where freezing conditions could occur or where accidental overflow could cause water damage to the home or property.

**DO NOT** install the humidifier where the temperature will exceed 180°F. Excessive heat may cause softening and distortion of the plastic housing. The installation of a water filter may reduce the potential clogging of the nozzle and solenoid valve in hard water applications.

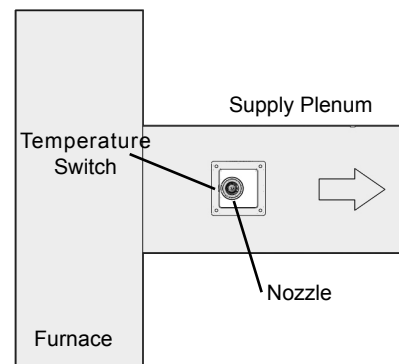
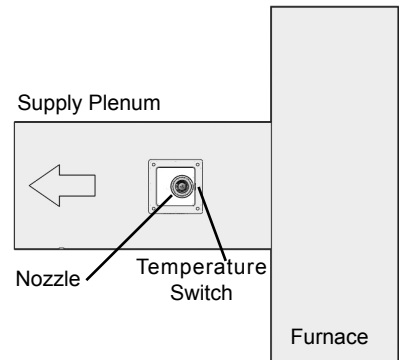
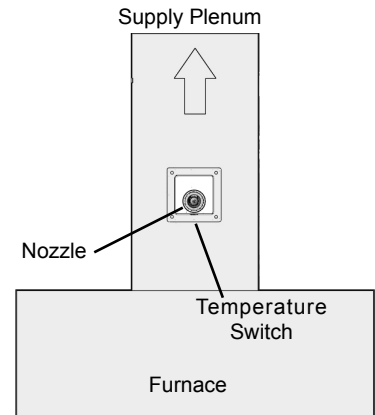

## Installation

Remember to select a location that is readily accessible for periodic inspection and cleaning of your humidifier.

### Mounting:

1. Read the instructions carefully prior to installing this product to ensure safe operation. Failure to follow these instructions could damage the humidifier or cause a hazardous condition. Property damage may result from improper installation.
2. Check the ratings given on the product to make sure it is suitable for your application. Do not install this product on heat pump systems.
3. Tape the template (included inside the carton) in place on the duct.
4. Drill the (4) 1/8" diameter holes as indicated. These are used to secure the unit to the duct
5. Neatly cut out the 3 1/8" x 3 1/8" opening according to the "cut out on line" indicator on the template. A portion of the unit will be inserted through this opening.
6. Remove all sharp edges and burrs to prevent damage to the unit or injury to yourself.
7. Remove the screw on the unit that secures the cover & nozzle assembly and pull back on the water fitting to release the humidifier cover from the housing. All of the components inside of the unit are attached to the cover and will come off with the cover.
8. Mount the unit housing with gasket (included) to the duct using the (4) mounting screws (included). Please refer to the illustration on the next page for reference.

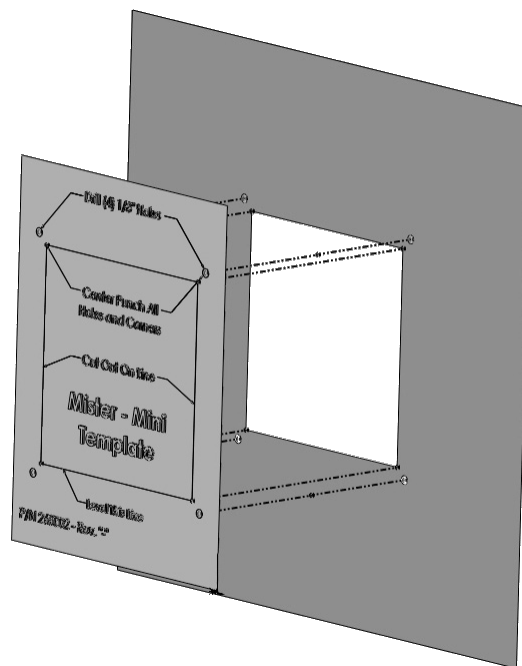

## Installation

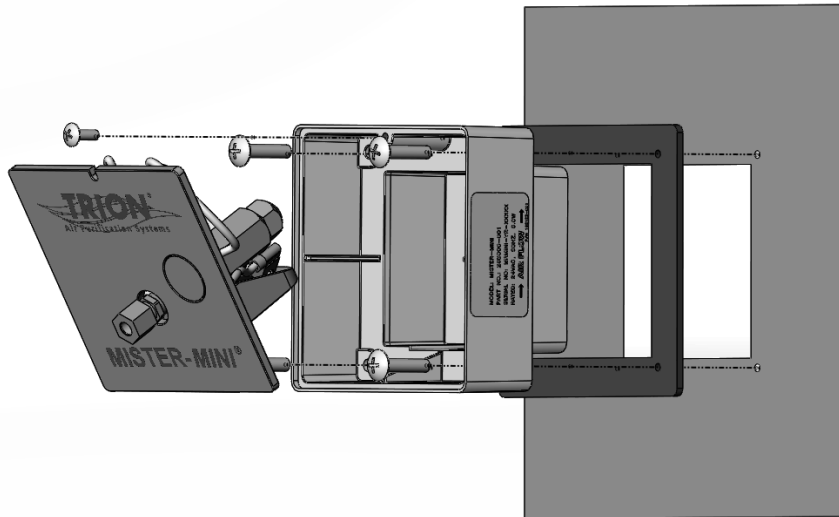

### Standard Wiring

This humidifier is intended to be wired directly to the integrated control panel on your furnace. The electrical tap will provide power to the humidifier whenever the circulating air blower is in operation.

Read the instructions in the furnace installation manual carefully before attempting installation or operation of the humidifier. Failure to follow these instructions may result in improper installation and therefore, void the manufacturer's warranty. The solenoid valve provided with the Mister-MINI is designed for 24VAC operation. Ensure that the proper diagram is used to connect power to the unit and humidistat.

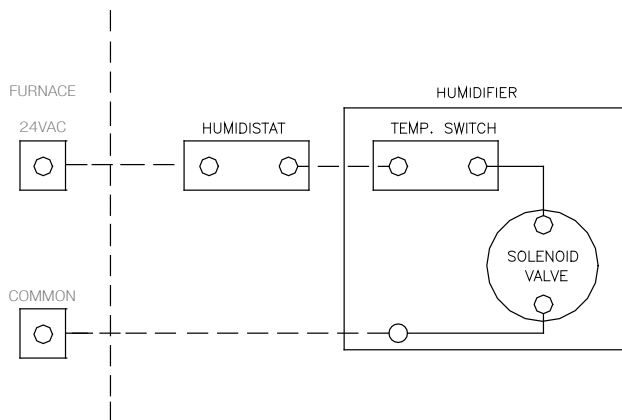

**⚠ WARNING ⚠**

 Improper electrical wiring can cause personal shock, personal injury, or property damage. It is required by local codes that the unit be installed by a properly qualified HVAC technician or electrician.

All wiring must be in accordance with NEC and existing local codes.

## Installation

### Optional Wiring

Electrical Connections (24 VAC)

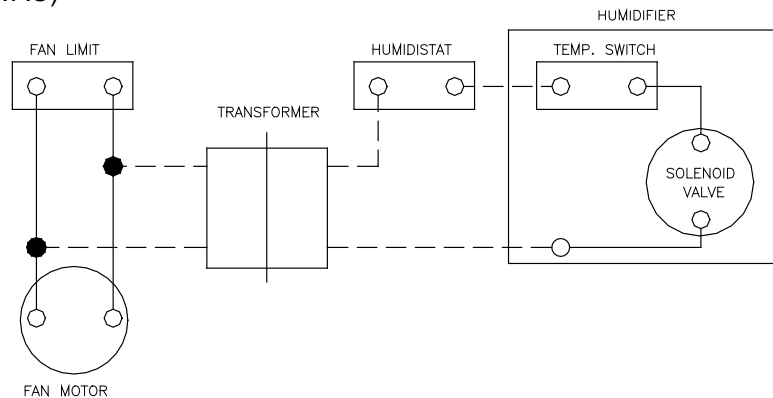

### Plumbing - USE COPPER WATER TUBING ONLY:

1. Install a saddle valve (not included) to a source of water per the instructions printed on the saddle valve package.
2. Fasten a copper water line (not included) of sufficient length to reach from the humidifier to the saddle valve.
3. With the end of the copper water line pointing into a bucket or pan, turn on the saddle valve to wash the tubing of any debris that may get stuck in the solenoid valve seat or clog the spray nozzle. When finished, turn the saddle valve off again.
4. Cut off any excess length of copper water tubing and connect it to the humidifier using the nut and ferrule provided on the humidifier. Slide the nut onto the copper water tubing and then slide the ferrule onto the water tubing. Assemble the nut to the compression fitting on the humidifier by turning it clockwise  $1\frac{1}{4}$  to  $1\frac{1}{2}$  turns past hand-tight to seal.
5. Turn the saddle valve back on and check the humidifier and tubing for leaks.

Nut & Ferrule  
supplied with saddle  
valve (not included  
with humidifier)

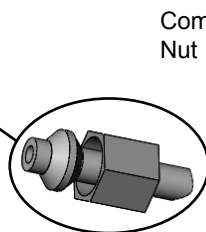

Compression  
Nut

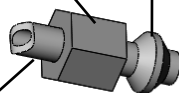

Copper  
Tubing

1/4"  
Compression  
Fitting

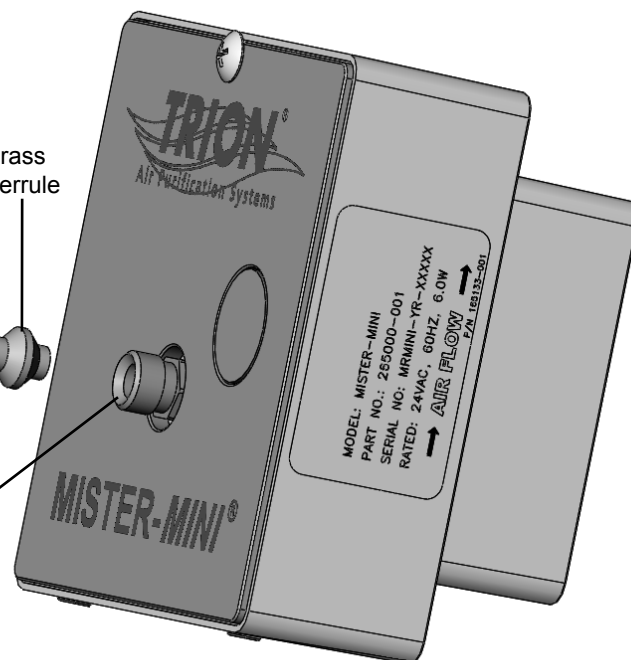

## Operation

### Overview:

Your atomizing mister type humidifier operates by dispersing a fine mist into the warm air plenum of your furnace. The water is then evaporated and carried into the home by the furnace air flow. This humidifier is recommended for areas where water mineral content is low. Otherwise, a fine accumulation of white dust may occur in either the ducts or living areas. High mineral content will also clog the nozzle causing an uneven spray pattern, excessive dripping, or total blockage of the nozzle tip. When wired properly, the humidifier will operate only when the plenum temperature rises to the internal thermostat setting, the humidistat senses a need for humidity, and the furnace blower is in operation. The internal thermostat controls the temperature at which the humidifier will turn on. The humidifier should activate after the furnace blower comes on and shut off before the furnace blower turns off. If this does not occur, readjust the furnace fan switch as required. If applicable, set the humidistat in the recommended range of 35-50% Relative Humidity for automatic humidity control during the heating season (a lower setting may be used to control condensation on single pane windows). Due to the operation cycle of the furnace and humidifier, it may take two to five days to reach the proper humidification level.

### Start-up & Operation:

1. Adjust the humidistat to the ON position and turn the furnace on.
2. Adjust the house thermostat to cause the furnace to operate. The heat and blower should turn on BEFORE the humidifier.
3. The solenoid valve will make an audible click when it operates, either on or off.
4. If necessary, adjust the furnace fan control to a lower setting to allow the blower to turn on before the humidifier turns on and the blower turns off after the humidifier is off.
5. Readjust the humidistat to the desired setting (35-50% Relative Humidity is recommended).
6. If condensation occurs on windows, lower the humidistat setting until the condensation has disappeared.

Recommended Relative Humidity Level vs. Outside Air Temperature	
Outside Temperature	Recommended Set-point
40°F	45% RH
30°F	40% RH
20°F	35% RH
10°F	30% RH
0°F	25% RH

**NOTE:** When shutting the humidifier down for the summer months, turn off the water and clean any mineral accumulation from the unit. Leave the water turned off. If the furnace fan is to be used for cooling purposes, disconnect power to the humidifier or turn the humidistat to the OFF position if applicable.

## Maintenance

Like your heating system and air conditioning unit, periodic maintenance and cleaning are required to ensure the safe and efficient operation of your humidifier. To improve the efficiency of your humidifier, and to reduce the possibility of a health hazard, it is recommended that you take the following precautions:

- Follow the manufacturer's recommended cleaning and maintenance instructions.
- The amount of minerals and other impurities in a water source can vary greatly, therefore the frequency of cleaning the humidifier also varies.
- During the heating season, check for film or scale build-up on the atomizing nozzle on a monthly basis. Establish a proper cleaning schedule to ensure the efficiency of the humidifier.
- At the end of the winter humidification season, drain and thoroughly clean the humidifier.

**NOTE:** The necessity to clean your humidifier is substantially the result of impurities coming in through your water supply which feeds the humidifier. Other household dust, containing biological and microbial contaminants can find its way into the air handling system and ultimately, the humidifier. The humidifier is not the source of these impurities.

### To clean and inspect the unit:

1. Turn the power to the furnace OFF.
2. Turn the humidistat to the OFF position.
3. Turn the water off at the saddle valve and remove the water tubing from the humidifier.
4. With the open end of the water line directed into a bucket or pan, turn on the water at the saddle valve to void the water line of any debris or particulates.
5. Remove the screw securing the unit cover to the housing and swing the cover down to gain access to the nozzle.
6. Carefully remove the nozzle from the adapter and proceed to clean the spray nozzle section.
7. Replace the spray nozzle with a clean one or new one of the same size and capacity as initially provided with the unit. Use care and secure tightly.
8. Swing the cover into place and fasten with screw.
9. Restore the water supply to the humidifier by reversing step 3.

### To check for leaks:

1. Turn the furnace and humidistat on and ensure that the humidifier has operated for at least one minute.
2. Remove the screw securing the cover to the housing and check nozzle for leakage.
3. If there is no leakage, return the unit to its original position and secure with screw.
4. After completing the cleaning, operate the solenoid to be sure it's operating properly.

## Maintenance

The following symptoms indicate that the spray nozzle requires cleaning or replacement. For best performance, nozzle should be replaced in lieu of cleaning.

- Larger spray pattern
- Non symmetrical spray pattern
- Constant water stream
- Not spraying water

### To Clean the Spray Nozzle

1. Turn the power to the furnace OFF.
2. Turn the humidistat to the lowest position.
3. Turn off the water supply at the saddle valve.
4. Remove the screw securing the cover of the humidifier to the housing.
5. Remove the cover assembly from the humidifier by tilting outward.
6. Be careful not to kink the water supply line or cause undue strain on the wiring.
7. Hold the nozzle adapter with a 3/4" wrench and using a 5/8" wrench, turn the spray nozzle counter clockwise and remove the nozzle.
8. Remove the screen from the nozzle by turning it counter clockwise.
9. Holding the spray nozzle with the 5/8" wrench, insert a 5/32" allen wrench into the set screw and turn it counter clockwise and remove the components.
10. Rinse and clean all parts. Suggested cleaners include 50/50 solution of white vinegar and water or liquid humidifier cleaner.
11. Using a razor blade, carefully clean the (4) slots on the director (see diagram below).
12. Reassemble the nozzle assembly, paying careful attention to the diagram below for the correct replacement of parts.
13. After completing the assembly, operate the unit to be sure it is functioning properly.

**NOTE:** It is recommended that the nozzle be replaced annually to avoid mineral build-up and possible clogging. Upon replacing the nozzle, check thoroughly for leaks.

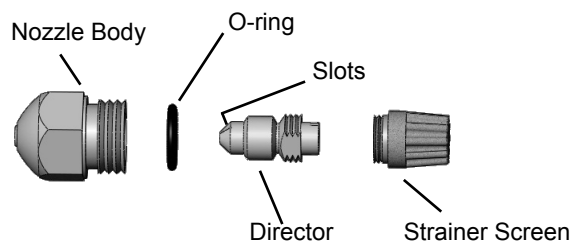

## Maintenance

The following symptoms indicate that cleaning the solenoid valve is required:

- Sluggish valve operation
- Excessive noise
- Constant water spray
- Streaming water

### To clean the solenoid valve:

1. Turn the power to the furnace OFF.
2. Turn the humidistat to the lowest position.
3. Turn off the water supply at the saddle valve.
4. Remove the screw securing the cover of the humidifier to the housing.
5. Remove the cover assembly from the humidifier by tilting outward.
6. Be careful not to kink the water supply line or cause undue strain on the wiring.
7. Remove the solenoid valve assembly from the cover using a Phillips head screwdriver.
8. Using a 3/4" wrench, remove the brass nozzle adapter from the OUT port of the valve body. Remove the compression fitting from the IN port of the valve.
9. Remove the coil from the assembly by turning the valve body counter clockwise.
10. Clean and remove all particulates from the brass fittings, filter, plunger/spring assembly and orifices in the valve body using a 50/50 solution of white vinegar and water.
11. Reassemble the parts, paying careful attention to the diagram below for the correct placement.
12. After completing the assembly, operate the unit to be sure it is functioning properly and check for leaks.

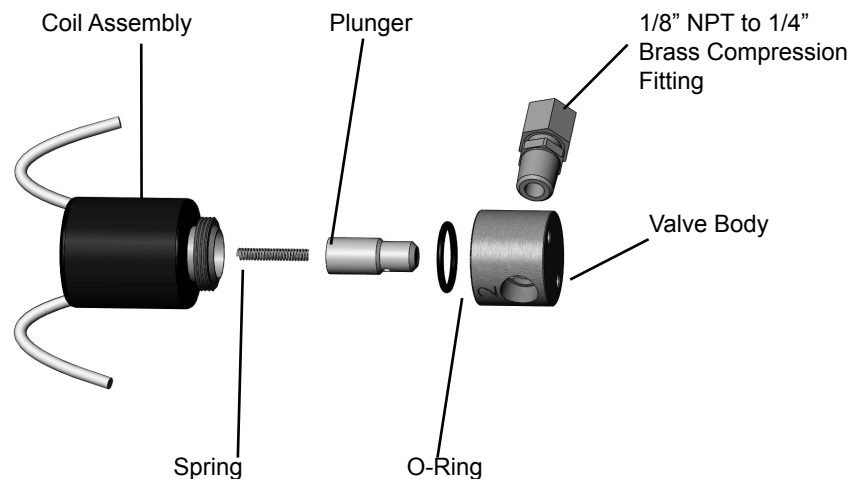

Solenoid Valve Assembly

## Unit Diagram

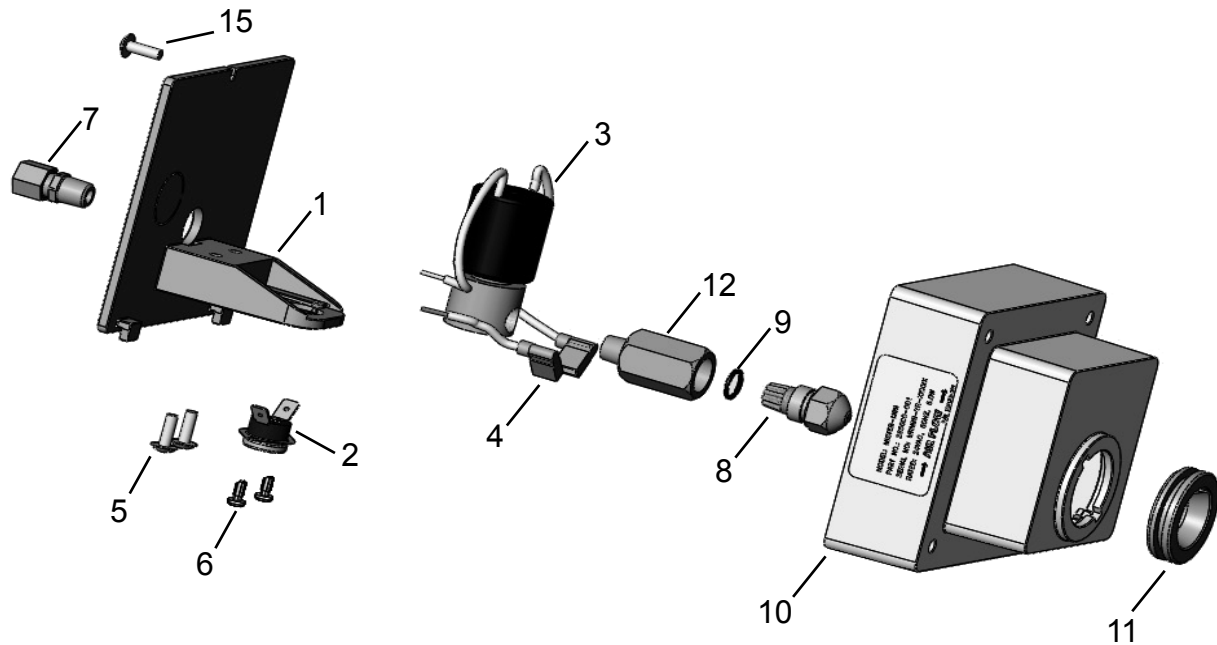

QTY.	ITEM NO.	PART NUMBER	DESCRIPTION
1	1	259959-001	COVER
1	2	265205-001	THERMOSTAT
1	3	266121-001	G-109C SOLENOID VALVE ASSEMBLY
1	4	266122-001	WIRE ASSEMBLY
2	5	EST-1434	SCREW, SST MACH M4 x 6MM
2	6	142983-003	CHRISTMAS TREE CLIP
1	7	AH-25	1/8" NPT x 1/4" COMPRESSION FITTING
1	8	12006-01	WATER NOZZLE W/FILTER
1	9	160	"O" RING
1	10	259960-001	CASE
1	11	265165-001	GROMMET
1	12	165007-001	NOZZLE ADAPTER
1	13	265037-001	GASKET MISTER-MINI (not shown)
1	14	265160-001	HUMIDISTAT, MECHANICAL (not shown)
1	15	2034	PHILLIPS SCREW #8 - 1/2" S/S

## Warranty

### Humidifier 5-Year Limited Warranty

This limited warranty covers TRION Residential Type Humidifiers, excluding duct work, wiring and installation. TRION warrants that all new TRION humidifiers are free from defects in material and workmanship under normal, non-commercial use and service. TRION will remedy any covered defects if they appear within 60 months from the date of original installation & subject to the terms and conditions of this Limited 5-Year Warranty stated below:

1. THIS LIMITED 5-YEAR WARRANTY is granted by TRION Customer Service, 101 McNeill Road, Sanford, NC 27330.
2. This warranty shall extend only to any non-commercial owner who has purchased the residential humidifier other than for purposes of resale.
3. All components are covered by this limited warranty except expendable items, such as evaporative pads, media filter pads and nozzles.
4. If, within the warranty period, any TRION residential humidifier unit or component requires service it must be performed by a competent heating and/or air conditioning contractor (preferably the installing contractor). TRION will not pay shipping charges, or labor charges to remove or replace such defective parts or components. If the part or component is found by inspection to contain such defective material and workmanship it will be either repaired or exchanged free of charge at TRION's option, and returned freight collect.
5. In order to obtain the benefits of this limited 5-year warranty, the owner must notify the dealer or distributor of any defect within 30 days of its discovery. If after reasonable time you have not received an adequate response from the dealer or distributor, notify in writing to TRION Customer Service 101 McNeill Road, Sanford, NC 27330, or call 1-800-884-0002 or email customerservice@trioniaq.com Humidifiers which have been installed or become part of real estate cannot be returned. TRION will receive, freight prepaid, only removable parts or components of such defective humidifiers.
6. This limited warranty does not apply to any part or component that is damaged in transit or in handling, has been subject to misuse, neglect or accident; has not been installed, operated and serviced according to TRION's instructions; has been operated beyond the factory rated capacity; or altered in any such way that its performance is affected. There is no warranty due to neglect, alteration or ordinary wear and tear. TRION's liability is limited to replacement of defective parts or components and does not include the payment of the cost of labor charges to remove or replace such defective components or parts.
7. TRION will not be responsible for loss of use of any product; loss of time, inconvenience, or any other indirect, incidental or consequential damages with respect to person or property, whether as a result of breach of warranty, neglect or otherwise. SOME STATES DO NOT ALLOW THE EXCLUSION OR LIMITATION OF INCIDENTAL OR CONSEQUENTIAL DAMAGES, SO THE LIMITATION OR EXCLUSION IN THE PRECEDING SENTENCE MAY NOT APPLY TO YOU.
8. THIS WARRANTY GIVES YOU SPECIFIC RIGHTS, AND YOU MAY ALSO HAVE OTHER RIGHTS WHICH VARY FROM STATE TO STATE.
9. Any warranty by TRION of merchantability, fitness for use or any other warranty (express, implied or statutory), representation or guarantee other than those set forth herein, shall expire at the expiration date of this express limited warranty. SOME STATES DO NOT ALLOW LIMITATIONS ON HOW LONG AN IMPLIED WARRANTY LASTS, SO THE LIMITATION IN THE PRECEDING SENTENCE MAY NOT APPLY TO YOU.
10. TRION reserves the right to make changes in the design and material of its products without incurring any obligation to incorporate such changes in units completed on the effective date of such change.

